

In SANS 10105 you will find the Minimum water pressure for both the hydrant and the hose reel.  
Which is **300KPA – Manufacturing Standard SANS 543**

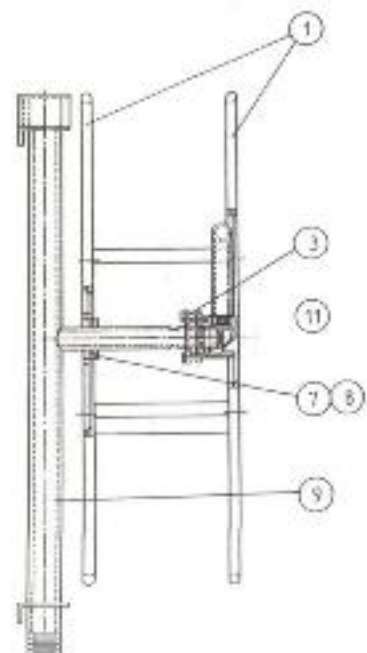

<p><b>1 Front &amp; Back plates</b></p> <p><b>2 Curved Plate</b></p> <p><b>3 Waterway assembly</b></p> <p><b>4 Washer</b></p> <p><b>5 Nut</b></p> <p><b>6 Bolt</b></p>	<p><b>7 Back plate Plastic Bush</b></p> <p><b>8 Pop rivets</b></p> <p><b>9 Header Bracket</b></p> <p><b>10 Front plate mounting screws</b></p> <p><b>11 Hose Run off shackle</b></p> <p><b>12 Instruction Label</b></p>
--	---

<b>Maintenance of hose reels</b>
<b>Theory and Practical</b>

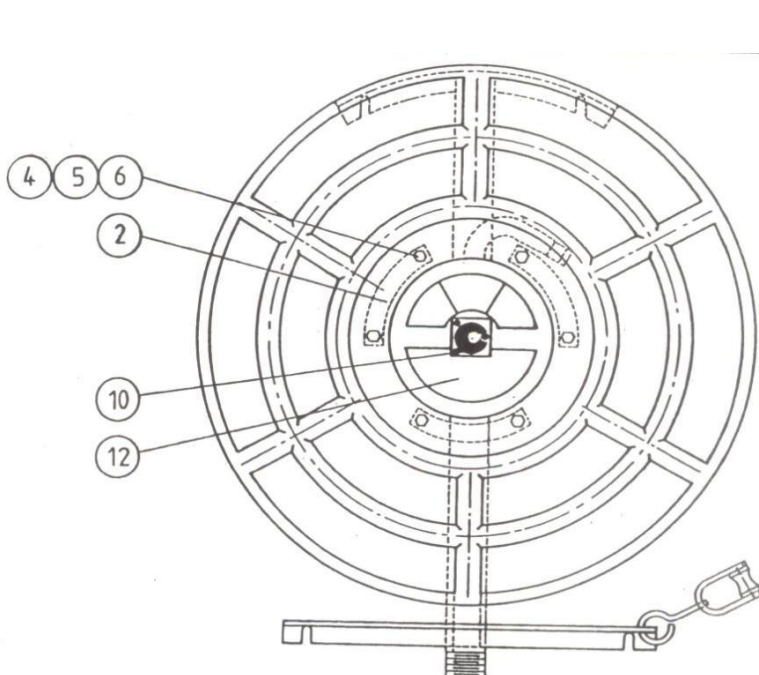



## TOOL BOX 033- HOSEREEL SERVICE / FAULT FINDING

**Risk Assessment: Is there any electrical cables and / or electrical machinery near the reel. If Yes REPORT TO THE RESPONSIBLE PERSON and do not service.**

### **Task Procedure**

1. **Check last service date and still sealed**
2. **Check general condition and security**
3. **Check arrow direction on CP Valve Pointing towards reel. This is a one way valve**
4. **Open water supply and check for leaks. Ensure Nozzle in closed Position  
Run out hose checking for damage to the shackle and hose such as cuts cracks kinks,  
and that the length is no longer than 30metres and not shorter than 28metres  
Further check for leaks and for rusting around waterway area**
5. **Open nozzle check the jet range: standard nozzle not less than 5 metres**
6. **Turn off water and release pressure on hose. Attach service label to inside reel as closed to the waterway as possible, and roll up hose.**

**7. Carryout bucket. ( If you require to determine the flow rate which is 0.5ltrs per second) (Not Required by SANS 1475-2)**

**Use Pre marked bucket at 5ltrs. Turn water on and time, and it should not take more than 10seconds which is 0.5ltrs per second.**

**If it does not reach the timing factor repeat. If still NO remove internal service label. Roll up hose and remove external service label. Mark outer drum "No Water"  
Report to CUSTOM both VERBALLY and ON JOB CARD**

**This is not totally accurate (pressure you would have to fit a gauge). But you can safely say that the pressure is at least 300Kpa (SANS 10105-2)**

**Note No7 is not a requirement under SANS 1475 Part2**

8. **Open nozzle and bleed in an action of pumping up and down to bring water level below the waterway. (Like milking a cow).  
You can close or keep the nozzle open.  
But if you leave it in the closed position and there is a problem. The water pressure on the waterway will build up and maybe lead to further repairs required.**
9. **Fit seal in such a way that it will have to be broken to use the equipment. Not on the hose to CP valve. But fitted between nozzle and hose to CP Valve.**
10. **Fit service label to drum with the following in the full weight block " Min 5 metres"**  
**Questions and answers (ask student)**



## TOOL BOX 033\_HOSEREEL SERVICE / FAULT FINDING

### **Fault Finding**

#### **1. No Water:**

*During your service procedure, and you have checked the arrow direction on the Control Valve. You hear water entering the system but little or none is coming out of the Nozzle.*

*Remove nozzle:*

*Water flows: Unblock or Replace Nozzle.*

#### **2. Missing or broken mounting bolts:**

*Fit missing bolt or remove frame and remove broken bolt. If there is a joint under the Control Valve you should be able to swing the reel assembly forward (remove hose to reduce weight) without switching off at the mains. If there is no joint you will have to report to the Responsible Person*

#### **3. Control Valve fitted with the arrow direction facing the wrong way:**

*As this is a one-way valve remove all service labels and mark no water. Report to the responsible person.*

#### **4. Leaking Reel after service:**

*In this case you may not pick up a problem during the service, and it may only appear as few days, weeks later. If you have serviced unit correctly, and the seal is not broken the problem is the Control Valve washer.*

*This is not part of the service (Inspection only during service) Report to the responsible person.*

*If you do intend to repair it you will have to have the water switched off at the mains.*

*It is very important that everybody that is going to be effect with the water being switched off is informed.*

*You should ensure that the Responsible person takes this responsibility, and not yourself or your company.*

*Once water is off on the modern Control Valves it's as simple as changing a tap washer, and on the older type the whole unit will have to be replaced.*

#### **5. Waterway Leaks:**

*You have two types of water ways "O"Ring and Gland Packing.*

##### **"O" Ring Type:**

*Ensure as much water has been drained*

- A. Remove Hose.**
- B. Remove drum and waterway assembly**
- C. Remove the three screw from the front plate behind the instruction label**
  
- D. Remove the waterway from the drum**
- E. Remove the circlip from the recess, and pull out the shaft**



- F. Remove the old "O" rings, and clean the shaft / body**
- G. Refit new "O" rings, lubricate, and refit shaft**
- H. Refit the circlip ensuring correctly site in the grove. (failure to do this, and the drum will fly off under pressure)**
- I. Refit waterway to the drum with the three screws**
- J. Use thread tape for the threaded part of the shaft, and refit to the header bracket**
- K. Refit hose, and slowly open the Control Valve.**

**At this stage there will be a slight leak until the waterway has bedded in. Once leak has stopped close the Control Valve and release the water pressure. Repeat, and ensure leaks have stopped. Carry on and complete the service>**

### **Gland Packing Type:**

**This is the old type reel that Technicians are quick to condemn, when the repair is very simple saving the Responsible person a lot of unnecessary expense.**

**The main reason this type of reel is condemned apart from the usual rusting is the Technicians over tightening of bolts.**

- A. While the hose is rolled down and the leak is present check the two mountain bolt plates. If they are not straight and show bending it means they have been over tightened in the past and probably they have also been stretched – Result condemn.**
- B. If they have not been stretched tighten slightly ensuring the drum still rotates freely – Leak cured finish service.**
- C. Leak continues – Ensure the water is off and pressure is released.**
- D. Remove the two bolts securing the flange**
- E. Pull the drum forward and separate.**



- F. Remove the gland packing, and cut a new piece to the same lengths (5mm)**

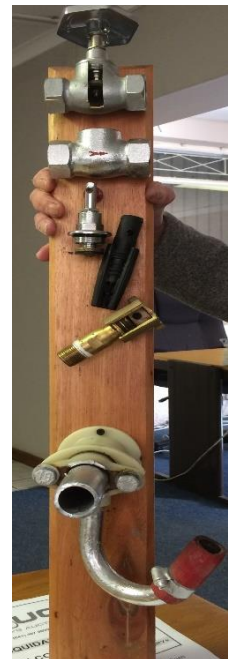



## TOOL BOX 033\_ HOSEREEL SERVICE / FAULT FINDING

*square graphite rope)*

**G. Clean parts concerned wind the new gland into place, refit parts together, insert bolts and tighten evenly ensuring the drum rotates freely.**

**H. Turn on the water pressure and check for leak**

### **IMPORTANT INFORMATION:**

**Some buildings have their fire circuits connected to the fire department, and or the warning alarm go off once you release water from the fire protection arrangement. Also especially high rise building parts or all of the system is supplied from tank usually situated on the top of the building.**

**Once you open a valve and release the water during testing. The pump kicks in and keeps the tank topped up.**

**If this pump doesn't kick in you will only be getting static water pressure, and may get the readings required throughout the building. You will assume the service work is to the standards required. But in fact you have depleted the water in the tank, and should there be an incident the equipment will not work.**

**Before you start you must pose all the above questions to the client. If you find the pump switched off or the tank inlet valve in the closed position. Ask the question why.**

**If the answer is they do not know why – Then tell them to find out before you perform any work.**

**There might be a leak or other fault for the protection system to be switched off.**

**If the client tells you to just turn the equipment on – Refuse, and tell them they must perform this task of switching on. ( You flood the place – They will hold you and your company responsible for any damage caused).**

**Also if the alarms go off and there is a feed back to the Fire Department – You and your company will be responsible for the call out fees.**

**If at any time you switch the water supply to any fire protection equipment**

- 1. The fire department should be informed**
- 2. The client needs to inform the insurance company and anybody who is going to be affected by the switch off.**

**Before a hose reel is moved or installed a design must be submitted for approval to the fire department – Original fire Plans cannot be altered.**

### **SANS 10400W**

#### **4.4 Isolating valves**

**An isolating valve shall be fitted in a fire installation at a position that is not more than 1,5m inside the boundary of the site, and shall be clearly marked as such.**

**Not counting the feed pipe to the actual hose reel. The following applies.**

- 1 to 2 hose reels feed 25mm**
- 3 hose reels 32mm**
- 4 to 5 hose reels 40mm**



## TOOL BOX 033\_HOSEREEL SERVICE / FAULT FINDING

6 and above 50mm

**SANS 10252-1:2012**

### **Watersupply installations for buildings**

#### **7.2.2 Fire installations and combined installations**

**7.2.2.1** A water gauge pressure of at least **300 kPa** at the level of the highest protected point shall be maintained when one hose reel is in full operation in any combined installation.

**7.2.2.2** A fire installation or combined installation shall

a) be so constructed as to provide

- 1) a supply of water sufficient for the effective operation of the number of hose reels and hydrants that can be operated or come into operation simultaneously in any division, and
- 2) a flow pressure, at any hose reel or hydrant, of at least **300 kPa** and a flow rate of at least i) **30L/min** per hose reel, and  
ii) **1 200 L/min** per hydrant, and

b) incorporate devices that limit the gauge pressure at any hydrant valve to **600 kPa** under full flow conditions.

#### **7.8 Fire installations and combined installations**

##### **7.8.1**

##### **General**

**7.8.1.1** Any fire installation or combined installation shall be the subject of a rational design.

**7.8.1.2** The design shall make provision for the number of hose reels and hydrants that can be operated or can come into operation simultaneously in any division.

**7.8.1.3** Unless otherwise required, fire hydrants in any building that exceed 12 m in height, or when the total floor area of the building exceeds 1 000 m<sup>2</sup>, shall be provided on the basis of one hydrant per 1 000 m<sup>2</sup> of floor area for each floor or part thereof.

**7.8.1.4** Hydrants, although intended for use by the fire brigade, shall be situated in suitable positions subject to direction by the local authority.

##### **7.8.2 Pipe sizes**

**7.8.2.1** Pipes in any fire installation or combined installation shall be sized according to a rational design and in accordance with 7.6, where appropriate.

**7.8.2.2** In any fire installation, a) the nominal diameter of



## TOOL BOX 033\_ HOSEREEL SERVICE / FAULT FINDING

- 1) a communication pipe serving such installation shall be at least 75 mm,
- 2) a pipe supplying water to a fire hydrant shall be at least 75 mm, except that where the length of such pipe exceeds 50 m, the nominal diameter of such pipe shall be at least 100 mm, and
- 3) a service pipe supplying water to a hose reel on any one storey of a building shall be at least
  - i) 25 mm, if it serves one or two hose reels,
  - ii) 32 mm, if it serves three hose reels,
  - iii) 40 mm, if it serves four or five hose reels, and
  - iv) 50 mm, if it serves more than five hose reels.

### Finally Note:

*Our mandate is from above the CP Valve up, and this training in no way is authoring you to perform any type of repairs below the CP Valve .Repairs, Replacement, and installation are not sanctioned by SAQCC, and we will not be held responsible for any incident involving damage, injury or incorrect work procedures.*

THIS TALK HAS BEEN EXTRACTED FROM A TRAINING MANUAL

See Toolbox Talk 013- Hose reel tips

See Toolbox Talk 003-Hose Reels

<b>Presented By:</b>	<b>Date</b>	<b>Signature</b>
Name: _____	_____	_____

NAME	SIGNATURE	NAME	SIGNATURE